



## **ISM43439-WBP-L151-EVB**

802.11 b/g/n + 5.2 BT/BLE + PSoC 6 (Cortex M0 & M4)

# **Evaluation Board User's Manual**

## Table of Contents

1	PART NUMBER DETAIL DESCRIPTION.....	3
1.1	Ordering Information.....	3
2	OVERVIEW.....	3
3	FEATURES.....	4
3.1	Limitations.....	6
4	COMPLEMENTARY DOCUMENTATION.....	7
5	BLOCK DIAGRAM.....	7
6	FEATURES LIST.....	8
7	INTRODUCTION.....	9
7.1	Development System.....	9
7.2	ISM43439-WBP-L151-EVB APPLICATIONS.....	10
8	POWER SUPPLY.....	11
8.1	The ISM43439-WBP-L151-EVB board is designed to be powered by a 5v DC power supply. 11	
8.2	It is possible to configure the evaluation board to use any of following two sources for the power supply:.....	11
9	RESET SWITCH.....	11
9.1	The reset signal of the ISM43439-WBP-L151-EVB board is low active and the reset source includes:.....	11
10	UART.....	11
10.1	The primary UART and flow-control lines between U6 and the KitProg3 are hard-wired on the board. The UART Connection is between KitProg3 and PSoC 62 MCU.....	11
11	I2C.....	12
11.1	The ISM43439-WBP-L151-EVB board enables two channels of I2C function. One channel connects to J7 (Pin4 & Pin5). Another channel connects to J21 (pin11 & Pin13).....	12
12	ADC.....	12
12.1	The ISM43439-WBP-L151-EVB board enables three channels of ADC signals. The ADC connects to J21 (Pin7, Pin9), and J22(Pin21).....	12
13	I2S.....	12
13.1	The ISM43439-WBP-L151-EVB board enables I2S function. The I2S is connected to J21(pin30, pin26, pin16, pin14, pin17), J22 (Pin2), and J20 (Pin9).....	12
14	SPI.....	12
14.1	The ISM43439-WBP-L151-EVB board SPI function connects to J20 (Pin20, Pin22, Pin24 & Pin26) and connects to J20 (Pin3, Pin5, Pin7, Pin12, Pin14 & Pin30), J21 (Pin20, Pin18) 12	
15	QUAD SPI.....	13
15.1	The ISM43439-WBP-L151-EVB board QUAD SPI function connects to J20 (Pin28, Pin21, Pin11, Pin13), J11 (Pin2), J22 (Pin20).....	13
16	GPIO.....	13
16.1	The ISM43439-WBP-L151-EVB board GPIO function connects to J21 (Pin10, Pin4, Pin1) 13	

17	CONNECTOR CONFIGURATIONS.....	13
17.1	Connector Configuration Power Supply (Micro USB: P3).....	13
17.2	Connector Configuration Pin Header (JP7).....	14
17.3	Connector Configuration PIN Header (JP6).....	14
17.4	Connector Configuration PIN Header (U21).....	14
17.5	Connector Configuration PIN Header (J4).....	15
17.6	Connector Configuration PIN Header (U22).....	15
17.7	Connector Configuration PIN Header (J14).....	15
17.8	Connector Configuration J20 Function Pin Header.....	16
17.9	Connector Configuration J21 Function Pin Header.....	16
17.10	Connector Configuration J22 Function Pin Header.....	17
18	SCHEMATICS.....	18
18.1	ISM43439-WBP-L151SiP (System in Package), Module Schematic.....	18
18.2	ISM43439-WBP-L151-EVB Power Supply Schematic.....	19
18.3	ISM43439-WBP-L151-EVB PSoC MCU Schematic.....	19
18.4	ISM43439-WBP-L151-EVB 10-Pin SWD/JTAG Header Schematic.....	20
18.5	ISM43439-WBP-L151-EVB I2C Pull-Ups & Reset SW Schematics.....	20
18.6	ISM43439-WBP-L151-EVB UART w/ HWFC & I2C Schematics.....	21
18.7	ISM43439-WBP-L151-EVB Quad SPI NOR Flash Schematic.....	21
18.8	ISM43439-WBP-L151-EVB Antenna Schematic.....	22
18.9	ISM43439-WBP-L151-EVB External Programmer Debug Header (U6), Schematic. .	22
18.10	ISM43439-WBP-L151-EVB PSoC MCU Schematic.....	23
18.11	ISM43439-WBP-L151-EVB KitProg3 USB Schematic.....	24
19	REVISION CONTROL.....	25
20	CONTACT INFORMATION.....	25

# 1 PART NUMBER DETAIL DESCRIPTION

## 1.1 Ordering Information

Device	Description	Ordering Number
ISM43439-WBP-L151-EVB	2.4 Wi-Fi + BT/BLE + PSoC 6 (Cortex M0 & M4 MCU) Evaluation Board	ISM43439-WBP-L151-EVB

## 1.2 Limitations

Inventek Systems products are not authorized for use in safety-critical applications (such as life support) where a failure of the Inventek Systems product would reasonably be expected to cause severe personal injury or death.

# 2 OVERVIEW

The Inventek ISM43439-WBP-L151-EVB is an Infineon single-band IEEE 802.11n-compliant MAC/PHY, BT/BLE 5.2 Wi-Fi/BLE combo Radio (CYW43439), and Infineon PSoC 62 (CY8C6248), MCU Evaluation Board platform. Channel bandwidth of 20MHz is supported for IEEE 802.11n traffic. 2.4GHz internal power amplifiers and a Power Management Unit (PMU), with one switching regulator.

The ISM43439-WBP-L151-EVB integrates clock, Wi-Fi/BT, and front end into the smallest form factor LGA Module. The ISM43439-WBP-L151-EVB IEEE 802.11 b/g/n enables wireless connectivity to the simplest existing sensor products with minimal engineering effort. ISM43439WBP-L151-EVB reduces development time, lowers manufacturing costs, saves board space, simplifies certification compliance, and minimizes customer RF expertise required during development of target applications.

The ISM43439-WBP-L151-EVB provides the highest level of integration for a wireless system, with integrated single band Wi-Fi and BT/BLE based on Cypress' IEEE802.11 b/g/n single-stream and BT/BLE 5.2 with support for antenna diversity and provisions for supporting future specifications. The ISM43439-WBP-L151-EVB also supports BT 5.2LE Secure Connection via the Cypress stack. Integrated power amplifiers, LNAs and T/R switches for the 2.4 GHz WLAN band, are also included, greatly reducing the external part count, PCB footprint, and cost of the solution.

The ISM43439-WBP-L151-EVB small form-factor solution also minimizes external components to drive down cost for mass volumes and allows for handheld device flexibility in size, form and

function. Comprehensive power management circuitry and software ensure the system can meet the needs of high mobile devices that require minimal power consumption and reliable operations.

The ISM43439-WBP-L151-EVB module includes an Infineon PSoC 62 (CY8C6248), Cortex M0+M4 MCU. SPI and UART interfaces enable easy connection to an embedded design. The ISM43439-WBP-L151-EVB module requires no operating system. The ISM43439-WBP-L151-EVB module also fully supports Infineon Modus Platform SDK.

The ISM43439-WBP-L151-EVB is compatible with the Bluetooth Low Energy operating mode, which provides a dramatic reduction in the power consumption of the Bluetooth radio and

baseband. The primary application for this mode is to provide support for low data rate devices, such as sensors and remote controls.

The ISM43439-WBP-L151-EVB implements the highly sophisticated Enhanced Collaborative Coexistence algorithms and hardware mechanisms, allowing for an extremely collaborative Bluetooth coexistence scheme along with coexistence support for external radios such as cellular and LTE, GPS, and Ultra-Wideband. An independent, high-speed UART is provided for the Bluetooth host interface.

### 3 FEATURES

The ISM43439-WBP-L151-EVB supports the following WLAN, Bluetooth & MCU functions:

- PSoC 62 ARM 32-bit Cortex™- M0 + M4 with a frequency up to 100 MHz
  - ARM Cortex-M4 (100MHz)
  - ARM Cortex-M0 (50MHz)
  - 1MB of MCU internal Flash
  - 256KB of SRAM
  - 2MB Quad SPI Flash
  - SPI (supports Dual mode), USART, PCM
  - ADC, I2C, I2S, GPIO, Timers
  - JTAG
- Single-band 2.4 GHz b/g/n, 802.11b, 802.11g, 802.11n (single stream)
  - IEEE 802.11b 1 – 11 Mbps
  - IEEE 802.11g 6 – 54 Mbps
  - IEEE 802.11n (2.4 GHz) 7.2 – 150Mbps
- Support BT 5.2 COEX
- Infineon Modus Fully compatible

- IEEE 802.11b/g/n single-band radio with internal Power Amplifiers, LNAs and T/R switches
  
- Hardware Encryption WEP, WPA/WPA2
- Modulation Modes include:
  - Wi-Fi: CCK and OFDM with BPSK, QPSK, 16 QAM, 64QAM, 256QAM
  - BT: Dual-mode classic Bluetooth and Classic Low Energy operation
- Concurrent Bluetooth and WLAN operation
- Single antenna support
- Supports a single 2.4 GHz antenna shared between WLAN and Bluetooth
- BT host digital interface (can be used concurrently with above interface):
  - UART (up to 4 Mbps)
- Bluetooth v5.2 with integrated Class 1 PA
- Bluetooth 2.1+EDR, Bluetooth 3.0, Bluetooth 5.2 (Bluetooth Low Energy)
- Bluetooth v5.2LE Secure Connection via the Cypress BSA stack.
- ECI – enhanced coexistence support, ability to coordinate BT SCO transmissions around WLAN receives.
- I<sup>2</sup>S/PCM for BT audio
- HCI high-speed UART (H4, H4 +, H5) transport support
- Bluetooth low power inquiry and page scan
- Bluetooth Low Energy (BLE) support

The BBC supports all Bluetooth 5.2 features, with the following benefits:

- Dual-mode classic Bluetooth and classic Low Energy (BT and BLE) operation.
- Low Energy Physical Layer
- Low Energy Link Layer
- Enhancements to HCI for Low Energy
- Low Energy Direct Test mode
- AES encryption

## 4 COMPLEMENTARY DOCUMENTATION

- Evaluation Board
  - Evaluation Board Specification
    - Option for Chip Antenna or a u.fl external antenna.
  - EVB User's Guide
  - Design Guidelines

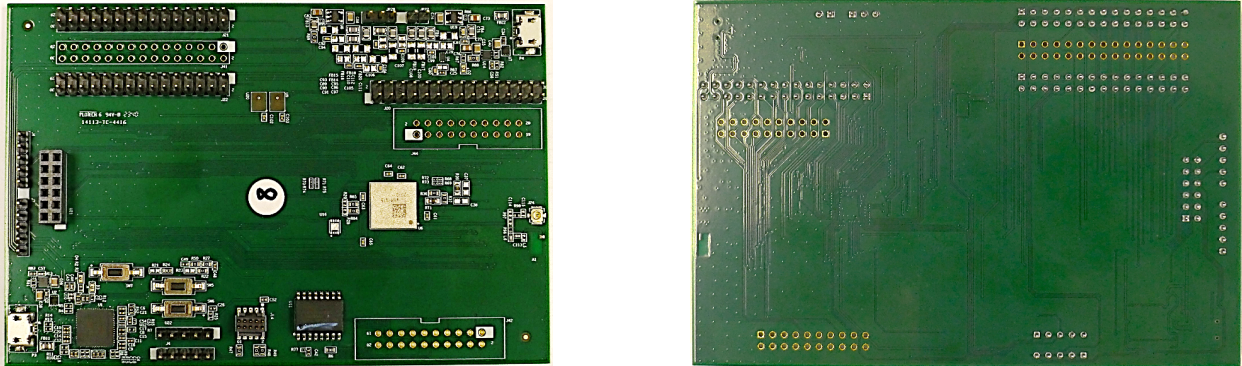

Figure 1: ISM43439-WBP-L151-EVB PCB

## 5 BLOCK DIAGRAM

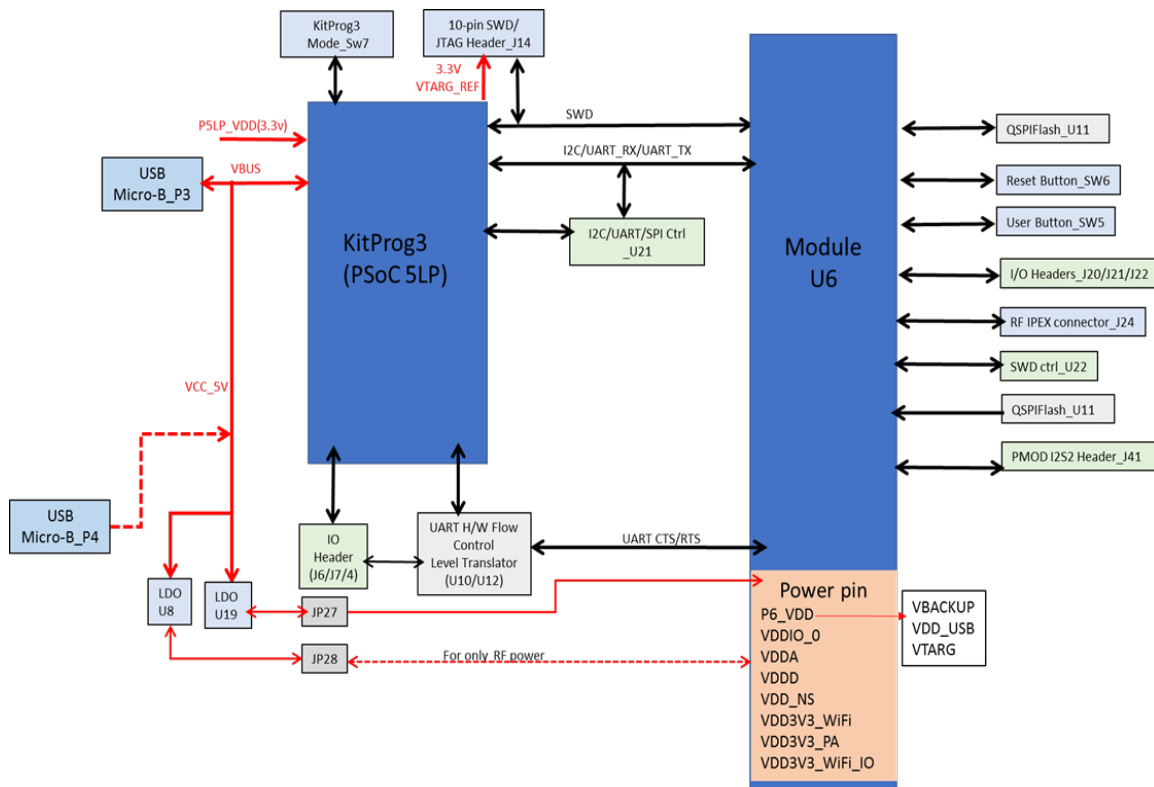

Figure 2: ISM43439-WBP-L151-EVB Block Diagram

## 6 FEATURES LIST

KitProg3	For Application to be downloaded to PSoC, also a programmer/debugger
USB-SERIAL UART	KitProg3 PSoC UART EVB interface for serial communications to a PC
EXPANSION HEADER	Facilitates custom sensor interfaces and expansion boards
RESET SWITCH	Enables a manual reset of the PsoC MCU
POWER SUPPLY	The EVB is powered directly from the USB interface, +5V power supply.
I2C	Intelligent Interface Controller
SPI	Serial Peripheral Interface
QSPI	Quad Serial Peripheral Interface
USART	Universal Synchronous/Asynchronous Receiver Transmitters
I2S	Integrated Inter-IC Sound Bus
ADC	Analog to Digital Converter (total of 3 channels)
TIM	Timers

**Table 1: ISM43439-WBP-L151-EVB Features List**

## 7 INTRODUCTION

### 7.1 Development System

The ISM43439-WBP-L151-EVB is a development system evaluation board that facilitates Wireless Internet Connectivity for Embedded Devices. The ISM43439-WBP-L151-EVB evaluation board includes the ISM43439-WBP-L151 SiP (System in Package), module consisting of an Infineon's AIROC™ CYW43439 Wi-Fi, Dual mode BT/BLE 5.2 Radio SoC and a PSoC62 ARM 32-bit MCU integrating both a Cortex M0 & M4 processor.

The development system, shown in Figure 3, is comprised of:

- A software Development Kit with a tool chain and build system, a Wi-Fi driver and software stack together with example applications. The Infineon Modus SDK run on a Windows OS.
- Applications developed using the ISM43439-WBP-L151-EVB SDK are downloaded via USB (or optionally via USB-JTAG J-Link) to an ISM43439-WBP-L151 module attached to a ISM43439-WBP-L151-EVB Evaluation Board.



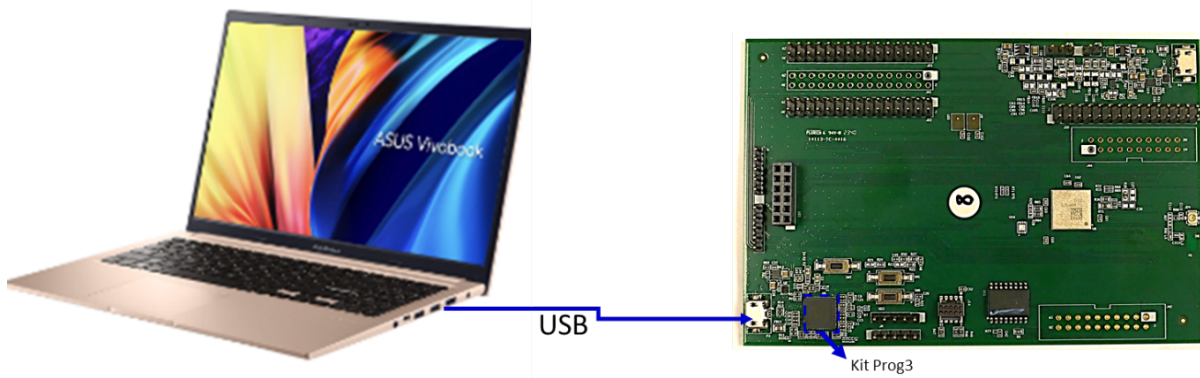

**Figure 3: ISM43439-WBP-L151-EVB Configuration**

- The KitProg3 is an onboard programmer/debugger with USB-I2C and USB-UART bridge functionality. Figure 4 shows the KitProg Ecosystem.

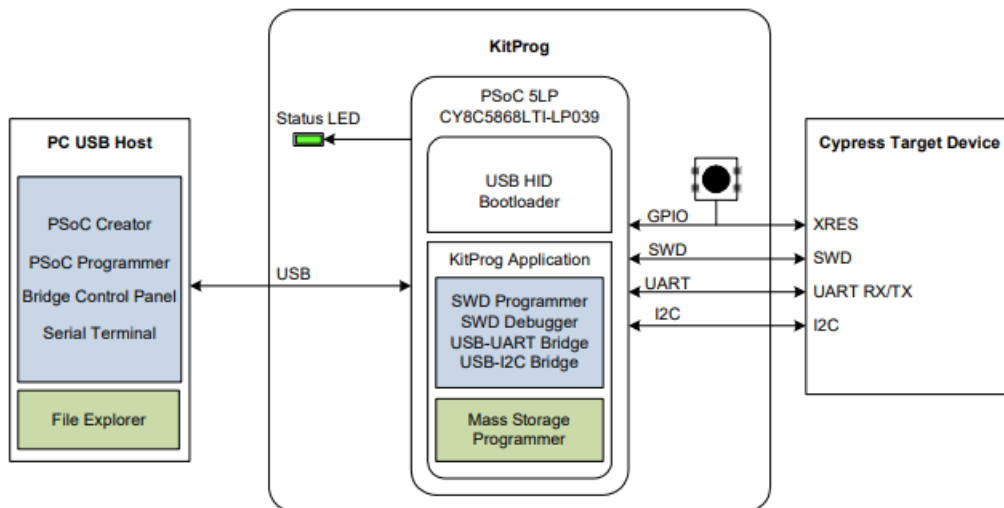

**Figure 4: ISM43439-WBP-L151-EVB KitProg3 Block Diagram**

## 7.2 ISM43439-WBP-L151-EVB APPLICATIONS

Applications developed using the ISM43439-WBP-L151-EVB and Modus SDK are downloaded via USB (or optionally via USB-JTAG J-Link) to the ISM4343-WBM-L151 module on the ISM43439-WBP-L151-EVB.

## 8 POWER SUPPLY

8.1 *The ISM43439-WBP-L151-EVB board is designed to be powered by a 5v DC power supply.*

8.2 *It is possible to configure the evaluation board to use any of following two sources for the power supply:*

- ◆ 5v DC power P4 is provided only for the U6 module usage, the USB Micro connector.
- ◆ 5v DC power provide full EVB power with 500mA limitation from P3, the USB Micro connector.
- ◆ JP27 and JP28 (Pin1 & Pin2), connections required.

## 9 RESET SWITCH

9.1 *The reset signal of the ISM43439-WBP-L151-EVB board is low active and the reset source includes:*

- ◆ The Reset switch button, SW6.
- ◆ SW6 connects the U6 Reset (XRES) pin to ground when pressed.
- ◆ The Debugging tools connector is U21.

## 10 UART

10.1 *The primary UART and flow-control lines between U6 and the KitProg3 are hard-wired on the board. The UART Connection is between KitProg3 and PSoC 62 MCU*

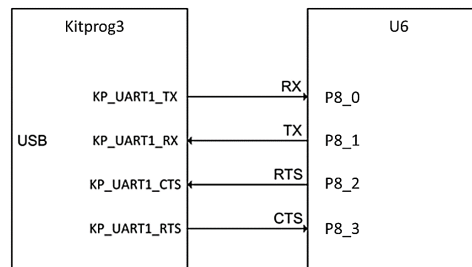

## 11 I2C

11.1 The ISM43439-WBP-L151-EVB board enables two channels of I2C function. One channel connects to J7 (Pin4 & Pin5). Another channel connects to J21 (pin11 & Pin13).

- ◆ I2C signal traces need to pull high.

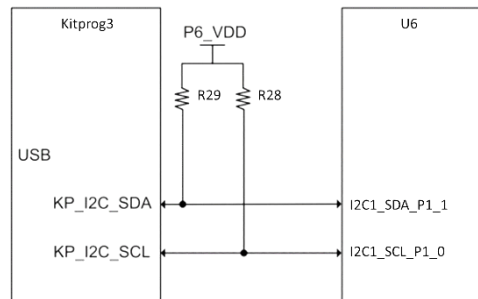

## 12 ADC

12.1 The ISM43439-WBP-L151-EVB board enables three channels of ADC signals. The ADC connects to J21 (Pin7, Pin9), and J22(Pin21).

## 13 I2S

13.1 The ISM43439-WBP-L151-EVB board enables I2S function. The I2S is connected to J21(pin30, pin26, pin16, pin14, pin17), J22 (Pin2), and J20 (Pin9)

## 14 SPI

14.1 The ISM43439-WBP-L151-EVB board SPI function connects to J20 (Pin20, Pin22, Pin24 & Pin26) and connects to J20 (Pin3, Pin5, Pin7, Pin12, Pin14 & Pin30), J21 (Pin20, Pin18)

- ◆ Note: The SPI1 is an internal connection to the internal Flash of the ISM43439-WBP-L151 module.

## 15 QUAD SPI

15.1 The ISM43439-WBP-L151-EVB board QUAD SPI function connects to J20 (Pin28, Pin21, Pin11, Pin13), J11 (Pin2), J22 (Pin20)

## 16 GPIO

16.1 The ISM43439-WBP-L151-EVB board GPIO function connects to J21 (Pin10, Pin4, Pin1)

## 17 CONNECTOR CONFIGURATIONS

17.1 Connector Configuration **Power Supply** (Micro USB: P3)

- The ISM43439-WBP-L151-EVB board can be powered from 5v DC power supply via the Micro USB connector (P3)
- 5v DC power P4 is provided only for U6 module option, the USB Micro connector.
- Micro USB Connector (P3)

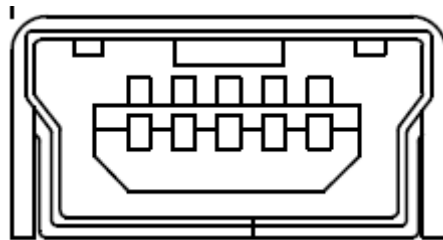

Front view

Pin	Description	Pin	Description
1	VBUS (5V)	4	NC
2	D- (connect to U1 pin 7)	5	GND
3	D+(connect to U1 pin 8)		

### 17.2 Connector Configuration Pin Header (JP7)

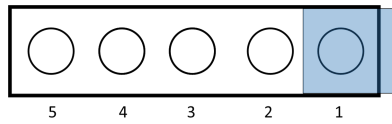

Pin	Description
1	VBUS
2	GND
3	VTARG
4	I2C_SCL
5	I2C_SDA

### 17.3 Connector Configuration PIN Header (JP6)

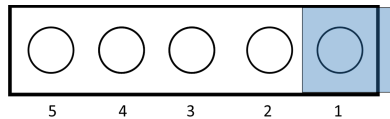

Pin	Description
1	GND
2	UART_RTS
3	UART_CTS
4	UART_RX
5	UART_TX

### 17.4 Connector Configuration PIN Header (U21)

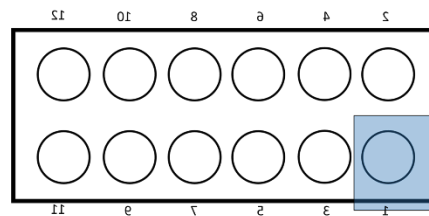

Pin	Description	Pin	Description
1	VTARG	7	SPI4_MOSI_P10_0
2	I2C_SDA	8	UART_RX
3	SPI4_SCK_P10_2	9	SPI4_MISO_P10_1
4	I2C_SCL	10	UART_RTS
5	SPI4_NSS_P10_3	11	UART_CTS
6	UART_TX	12	GND

### 17.5 Connector Configuration PIN Header (J4)

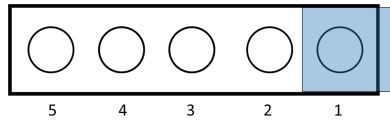

Pin	Description
1	VTARG
2	GND
3	RESET
4	SWDCLK
5	SWDIO

### 17.6 Connector Configuration PIN Header (U22)

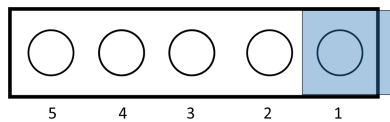

Pin	Description
1	TMS_SWDIO_P6_6
2	TCLK_SWCLK_P6_7
3	XRES
4	GND
5	VTARG

### 17.7 Connector Configuration PIN Header (J14)

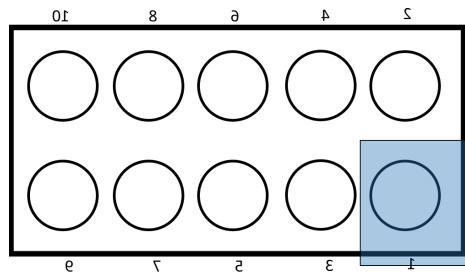

Pin	Description	Pin	Description
1	P6_VDD	6	TDO_SWO_P6_4
2	TMS_SWDIO_P6_6	7	GND
3	GND	8	TDI_P6_5
4	TCLK_SWCLK_P6_7	9	GND
5	GND	10	XRES

### 17.8 Connector Configuration J20 Function Pin Header

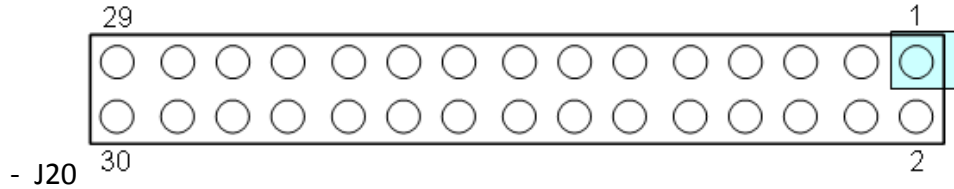

Pin	Description	Pin	Description
1	GND	2	GND
3	MICRO_SPI_MISO_P5_1	4	GND
5	MICRO_SPI_SCK_P5_2	6	TDI_P6_5
7	MICRO_SPI_NSS_P5_3	8	TDO_SWO_P6_4
9	I2S_TX_SDO_P13_3	10	EXT_LPO_IN
11	QSPI_DATA2_P11_4	12	MICRO_SPI2_MOSI_P9_0
13	QSPI_DATA1_P11_5	14	MICRO_SPI2_MISO_P9_1
15	BT_HOST_WAKE	16	P11_1_N
17	BT_DEV_WAKE	18	CLK_REQ
19	BT_PCM_CLK	20	SPI4_MOSI_P10_0
21	QSPI_DATA3_P11_3	22	SPI4_MISO_P10_1
23	USART1_TX_P8_1	24	SPI4_SCK_P10_2
25	USART1_RX_P8_0	26	SPI4_NSS_P10_3
27	USBDM	28	QSPI_CLK_P11_7
29	USBDM	30	MICRO_SPI_MOSI_P5_0

### 17.9 Connector Configuration J21 Function Pin Header

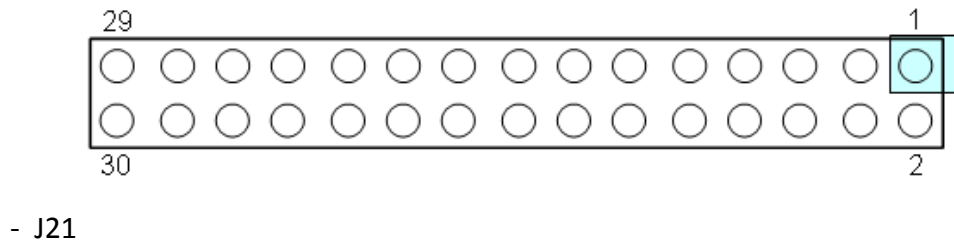

Pin	Description	Pin	Description
1	WIFI_GPIO_2	2	QSPI_DATA0_P11_6
3	P0_3	4	WLRG_GPIO
5	P0_2	6	USART6_RX_P5_4
7	MICRO_ADC3_P10_6	8	USART6_TX_P5_5
9	MICRO_ADC2_P10_5	10	WIFI_GPIO_1
11	I2C1_SCL_P1_0	12	WL_REG_ON
13	I2C1_SDA_P1_1	14	I2S_RX_WS_P13_5
15	P8_2_N	16	I2S_RX_SCK_P13_4
17	I2S_RX_SDO_P13_6	18	MICRO_SPI2_SCK_P9_2
19	P5_7	20	MICRO_SPI2_NSS_P9_3
21	P7_3	22	I2C2_SCL_P12_0

23	P8_3_N	24	I2C2_SDA_P12_1
25	P9_4_N	26	I2S_MCLK_P13_0
27	P7_7	28	P5_6
29	GND	30	I2S_TX_SCK_P13_1

### 17.10 Connector Configuration J22 Function Pin Header

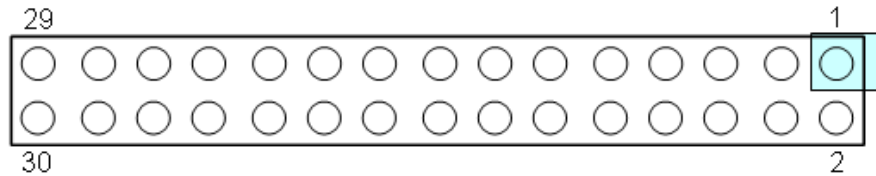

- J22

Pin	Description	Pin	Description
1	GND	2	I2S_TX_WS_P13_2
3	P5LP_VDD	4	P1_5
5	P5LP_XRES	6	GND
7	P5LP_SWDIO	8	BT_UART_RXD
9	P5LP_SWCLK	10	BT_UART_TXD
11	GND	12	BT_UART_CTS_L
13	GND	14	BT_UART_RTS_L
15	GND	16	P1_4
17	GND	18	BT_REG_ON
19	GND	20	QSPI_CS_P11_2
21	MICRO_ADC1_P10_4	22	WL_HOST_WAKE
23	P8_4	24	P11_0_N
25	BT_PCM_IN	26	P10_7_N
27	BT_PCM_OUT	28	P0_5
29	BT_PCM_SYNC	30	P9_7_N



# 18 SCHEMATICS

## 18.1 ISM43439-WBP-L151SiP (System in Package), Module Schematic

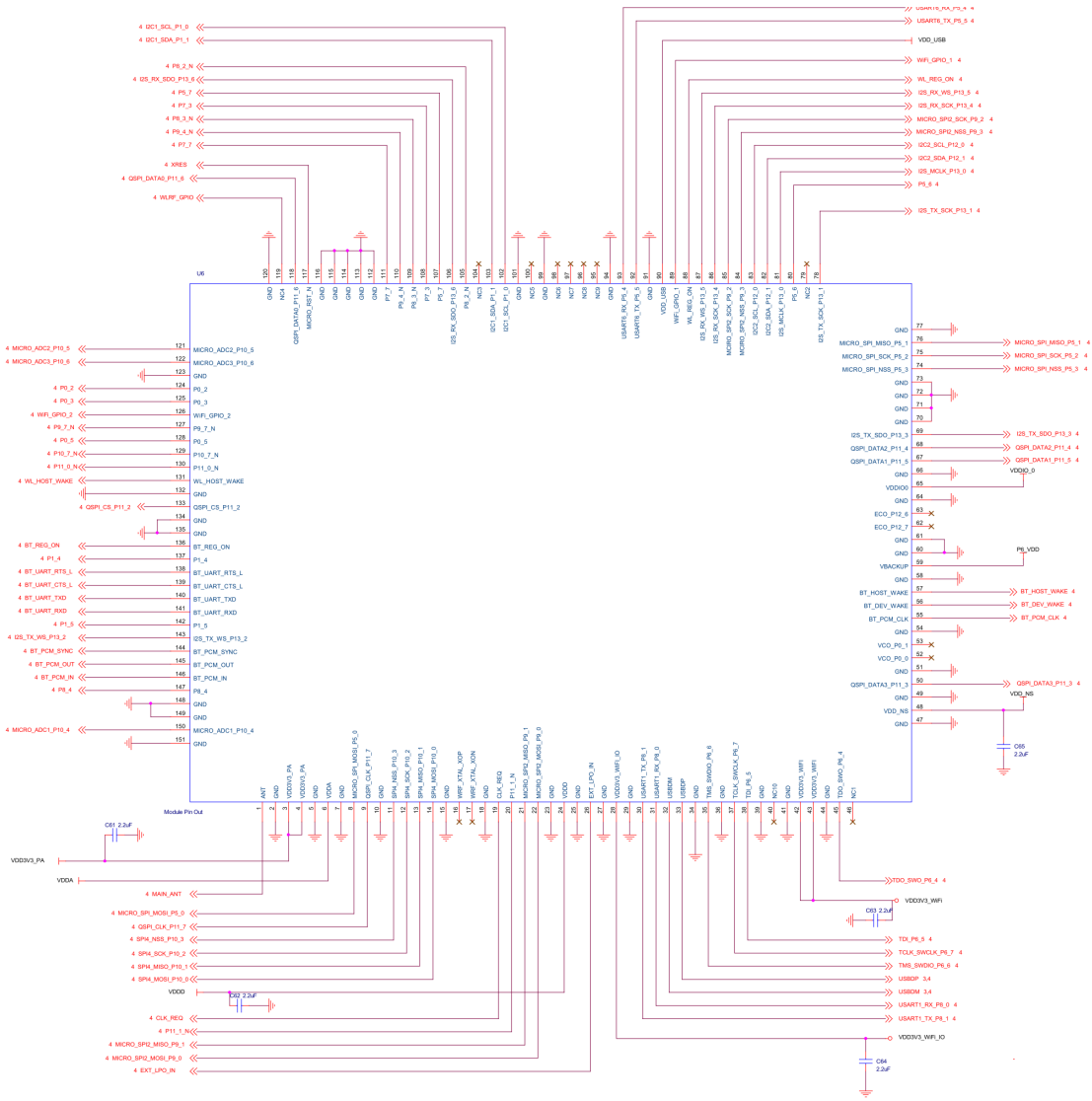



### 18.4 ISM43439-WBP-L151-EVB 10-Pin SWD/JTAG Header Schematic

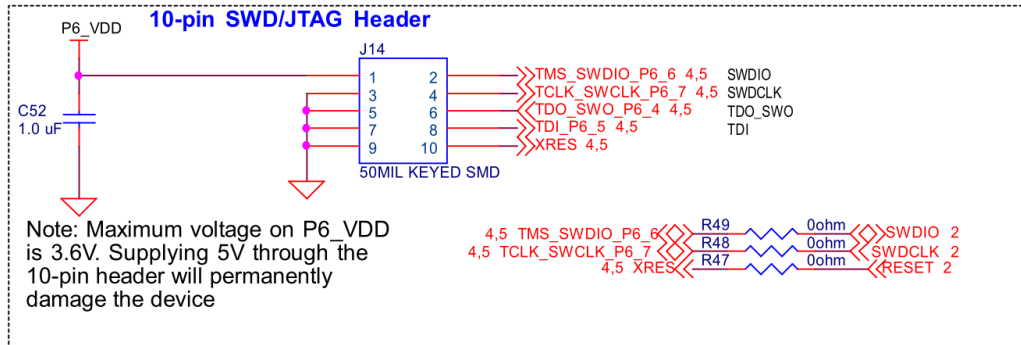

### 18.5 ISM43439-WBP-L151-EVB I2C Pull-Ups & Reset SW Schematics

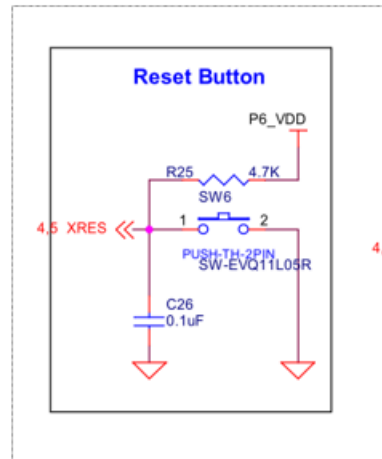
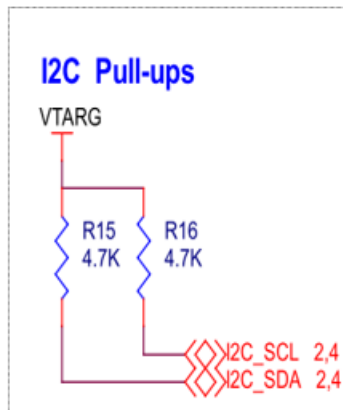

18.6 ISM43439-WBP-L151-EVB **UART w/ HWFC & I2C Schematics**

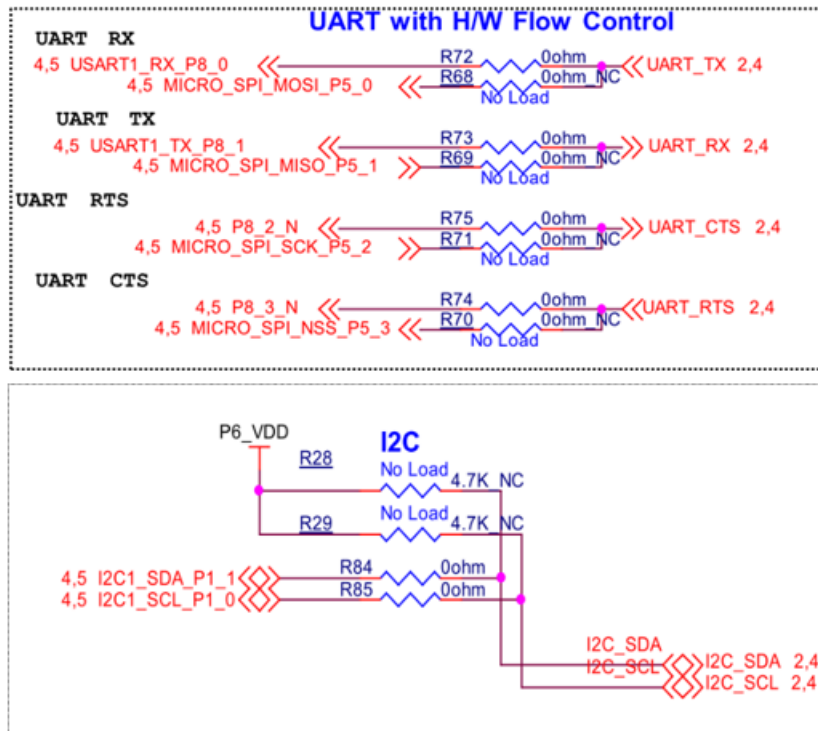

18.7 ISM43439-WBP-L151-EVB **Quad SPI NOR Flash Schematic**

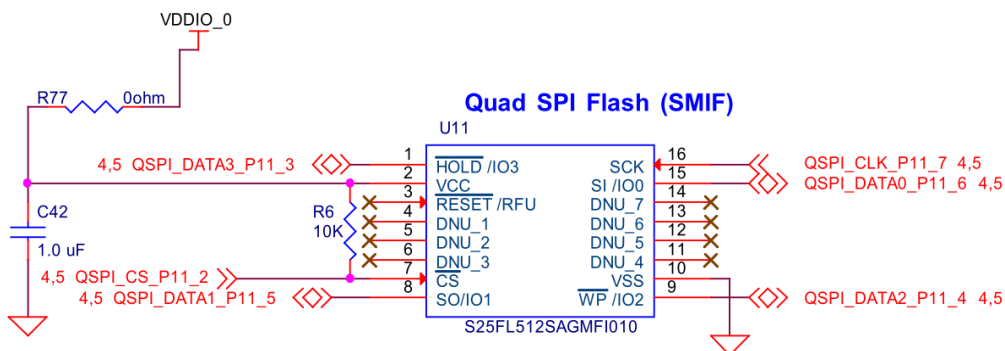

**18.8 ISM43439-WBP-L151-EVB Antenna Schematic**

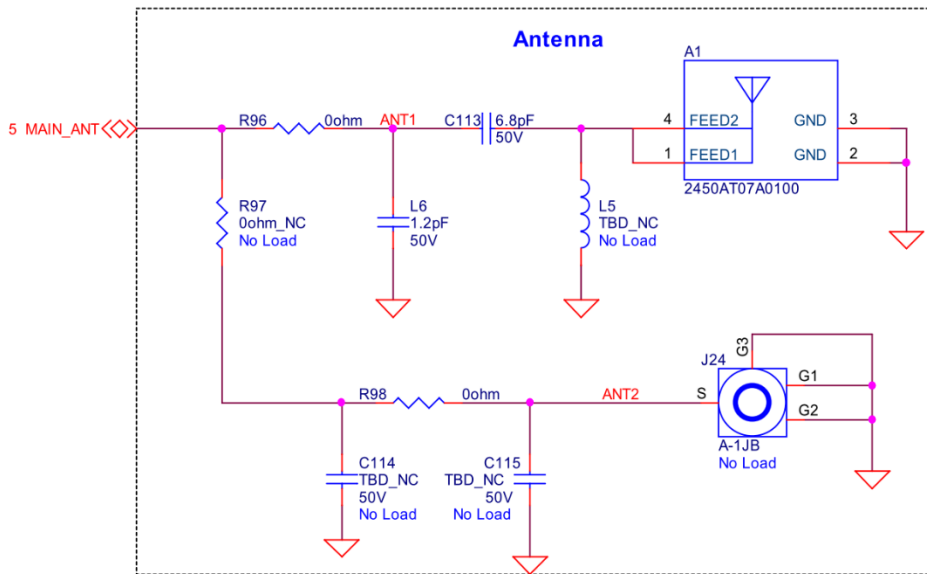

**18.9 ISM43439-WBP-L151-EVB External Programmer Debug Header (U6), Schematic**

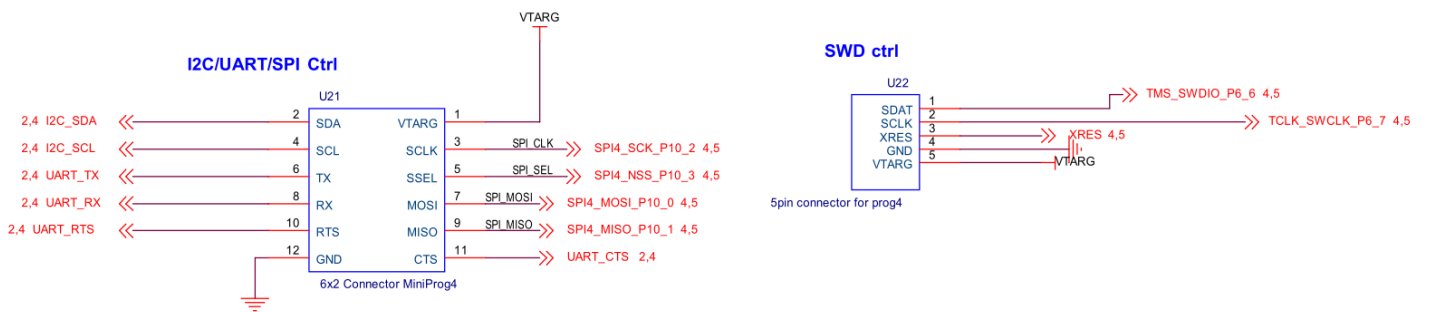



18.11 ISM43439-WBP-L151-EVB **KitProg3 USB Schematic**

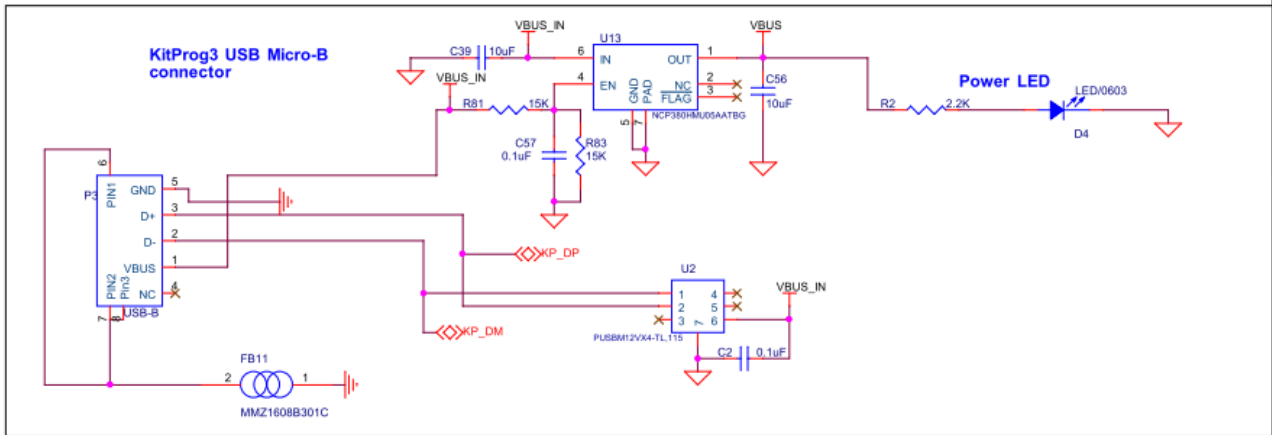

## 19 REVISION CONTROL

Document: ISM43439-WBP-L151-EVB	Wi-Fi + BT/BLE + PSoC 6 Module
External Release	DOC-DS-43439-1.0

Date	Author	Revision	Comment
12/1/2023	AS	1.0	Preliminary
12-17-23	AS	1.1	Figure 3 Update

## 20 CONTACT INFORMATION

Inventek Systems  
 100 Treble Cove Road  
 Suite 5  
 Billerica Ma, 01862  
 Tel: 978-667-1962  
[Sales@inventeksys.com](mailto:Sales@inventeksys.com)  
[www.inventeksys.com](http://www.inventeksys.com)

Copyright 2017, Inventek Systems. All Rights Reserved. This software, associated documentation, and materials ("Software"), referenced and provided with this documentation is owned by Inventek Systems and is protected by and subject to worldwide patent protection (United States and foreign), United States copyright laws and international treaty provisions. Therefore, you may use this Software only as provided in the license agreement accompanying the software package from which you obtained this Software.

("EULA"). If no EULA applies, Inventek Systems hereby grants you a personal, non-exclusive, non-transferable license to copy, modify, and compile the Software source code solely for use in connection with Inventek's integrated circuit products.

Any reproduction, modification, translation, compilation, or representation of this Software except as specified above is prohibited without the express written permission of Inventek. Disclaimer: THIS SOFTWARE IS PROVIDED AS-IS, WITH NO WARRANTY OF ANY KIND, EXPRESS OR IMPLIED, INCLUDING, BUT NOT LIMITED TO, NONINFRINGEMENT, IMPLIED WARRANTIES OF MERCHANTABILITY AND FITNESS FOR A PARTICULAR PURPOSE.

Inventek reserves the right to make changes to the Software without notice. Inventek does not assume any liability arising out of the application or use of the Software or any product or circuit described in the Software. Inventek does not authorize its products for use in any products where a malfunction or failure of the Inventek product may reasonably be expected to result in significant property damage, injury, or death ("High Risk Product"). By including Inventek's product in a High-Risk product, the manufacturer of such system or application assumes all risk of such use and in doing so agrees to indemnify Inventek against all liability. Inventek Systems reserves the right to make changes without further notice to any products or data herein to improve reliability, function, or design. The information contained within is believed to be accurate and reliable. However, Inventek does not assume any liability arising out of the application or use of this information, nor the application or use of any product or circuit described herein, neither does it convey any license under its patent rights nor the rights of others.